

CHARTER TOWNSHIP OF OAKLAND  
 BUILDING DEPARTMENT  
 4393 Collins Road  
 Rochester, Michigan 48306  
 (248) 651-6930

AS-BUILT CERTIFICATION

Address \_\_\_\_\_ Lot Number \_\_\_\_\_

Sidwell \_\_\_\_\_ Subdivision \_\_\_\_\_

Certified by Name \_\_\_\_\_  
 (Seal Required)

Firm \_\_\_\_\_

Address \_\_\_\_\_

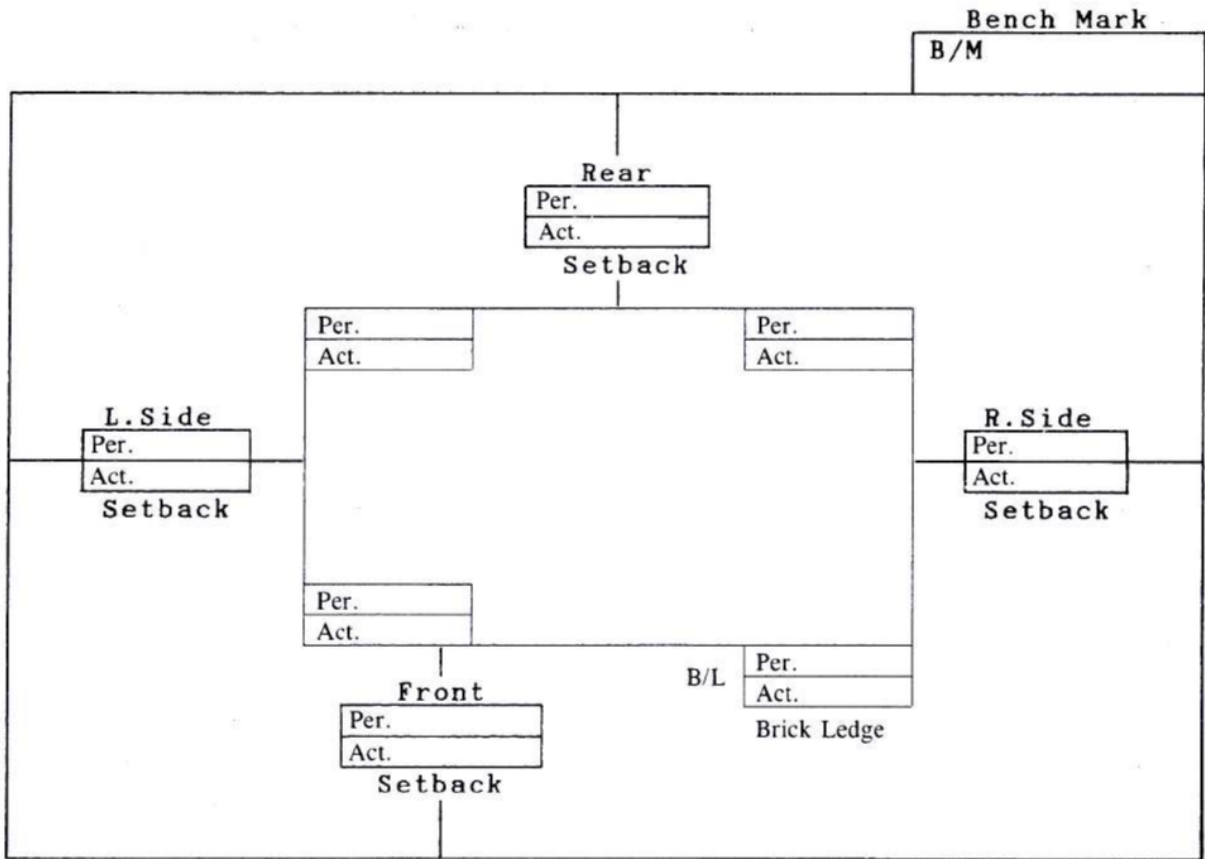

White - Engineer  
 Yellow - Builder  
 Pink - Office

1 2 6

REV. 12/94